

**WARREN
RUPP®**

Quality System
ISO9001 Certified

Environmental
Management System
ISO14001 Certified

IDEX
IDEX CORPORATION



CE

U.S. Patent #5,996,627 &
6,241,487
Other U.S. Patents Applied for



I M2 c/b T5
II 2GD b T5

SANDPIPER®
A WARREN RUPP PUMP BRAND

S1F Metallic Design Level 1 Ball Valve

**Air-Powered
Double-Diaphragm Pump**

ENGINEERING, PERFORMANCE
& CONSTRUCTION DATA

INTAKE/DISCHARGE PIPE SIZE	CAPACITY	AIR VALVE	SOLIDS-HANDLING	HEADS UP TO	DISPLACEMENT/STROKE
1" NPT(internal) 1" BSPT Tapered (internal)	0 to 45 gallons per minute (0 to 170 liters per minute)	No-lube, no-stall design	Up to .25 in. (6mm)	125 psi or 289 ft. of water (8.6 Kg/cm ² or 86 meters)	.11 Gallon / .42 liter

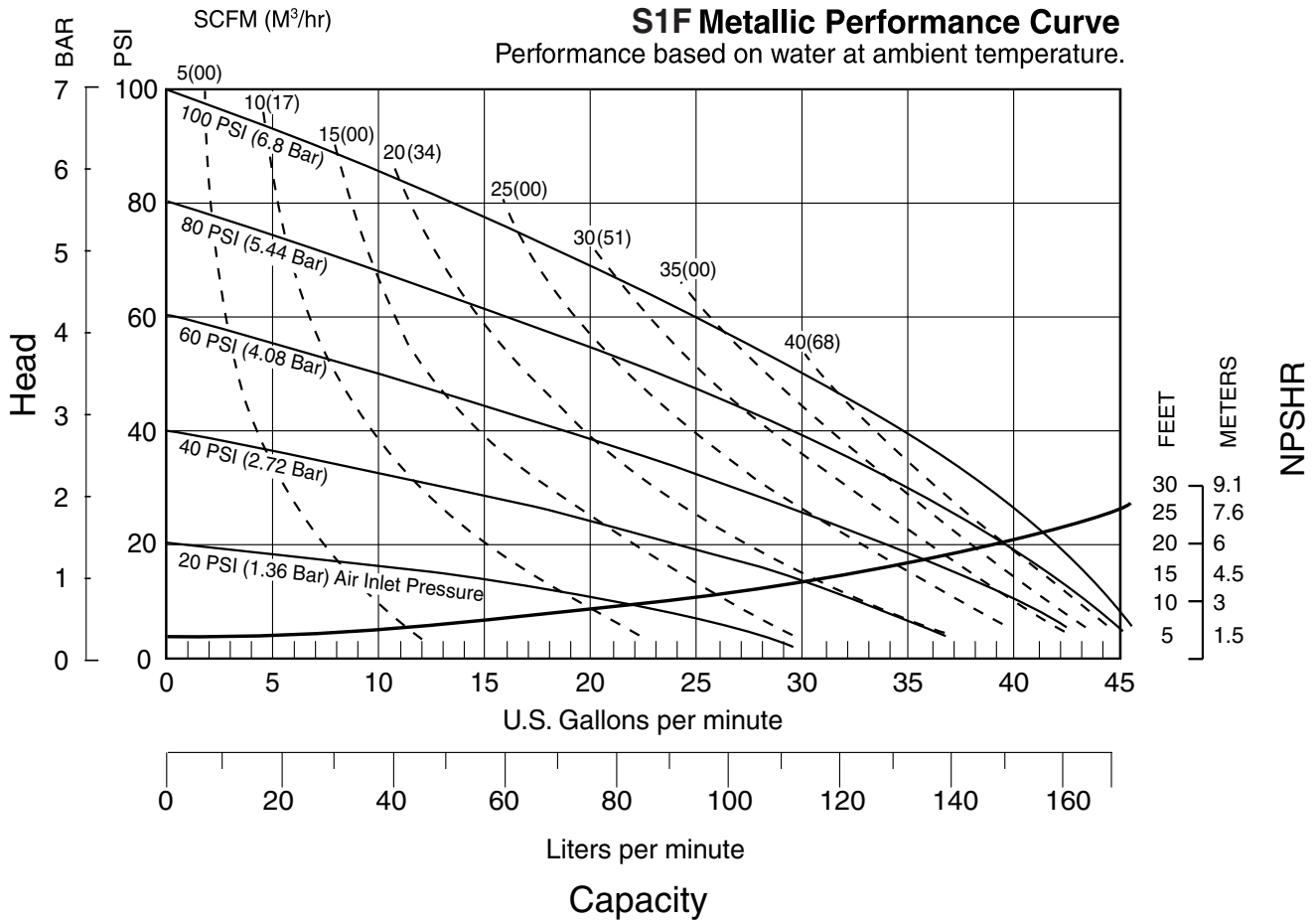

SANDPIPER® pumps are designed to be powered only by compressed air.

Explanation of Pump Nomenclature

S1F Metallic · Design Level 1 · Ball Valve

MODEL	Pump Brand	Pump Size	Check Valve Type	Design Level	Wetted Material	Diaphragm/Check Valve Materials	Check Valve Seat	Non-Wetted Material Options	Porting Options	Pump Style	Pump Options	Shipping Kit Options	Weight lbs. (kg)
S1FB1ABWANS000.	S	1F	B	1	A	B	W	A	N	S	0	00.	28 (13)
S1FB1AIWANS000.	S	1F	B	1	A	I	W	A	N	S	0	00.	28 (13)
S1FB1AGTANS000.	S	1F	B	1	A	G	T	A	N	S	0	00.	28 (13)
S1FB1ANWANS000.	S	1F	B	1	A	N	W	A	N	S	0	00.	28 (13)
S1FB1A1WANS000.	S	1F	B	1	A	1	W	A	N	S	0	00.	28 (13)
S1FB1ACTANS000.	S	1F	B	1	A	C	T	A	N	S	0	00.	28 (13)
S1FB1IBWANS000.	S	1F	B	1	I	B	W	A	N	S	0	00.	46 (21)
S1FB1IIWANS000.	S	1F	B	1	I	I	W	A	N	S	0	00.	46 (21)
S1FB1IGTANS000.	S	1F	B	1	I	G	T	A	N	S	0	00.	46 (21)
S1FB1INWANS000.	S	1F	B	1	I	N	W	A	N	S	0	00.	46 (21)
S1FB111WANS000.	S	1F	B	1	I	1	W	A	N	S	0	00.	46 (21)
S1FB1ICTANS000.	S	1F	B	1	I	C	T	A	N	S	0	00.	46 (21)
S1FB1IIWANS000.	S	1F	B	1	I	I	W	A	N	S	0	00.	46 (21)
S1FB1SBWANS000.	S	1F	B	1	S	B	W	A	N	S	0	00.	43 (20)
S1FB1SGTANS000.	S	1F	B	1	S	G	T	A	N	S	0	00.	43 (20)
S1FB1SNWANS000.	S	1F	B	1	S	N	W	A	N	S	0	00.	43 (20)
S1FB1S1WANS000.	S	1F	B	1	S	1	W	A	N	S	0	00.	43 (20)
S1FB1SCTANS000.	S	1F	B	1	S	C	T	A	N	S	0	00.	43 (20)

Pump Brand

S= SANDPIPER®

Pump Size

1F=1"

Check Valve Type

B= Ball

Design Level

1= Design Level

Wetted Material

A= Aluminum

I = Cast Iron

S= Stainless Steel

Diaphragm Check Valve Materials

1= Santoprene®/Santoprene®

B= Buna/Buna

C= Viton®/PTFE

G=PTFE-Neoprene/PTFE

I = EPDM/Santoprene®

N=Neoprene/Neoprene

W=Neoprene Bonded uniRupp®/PTFE

X= Santoprene® Bonded uniRupp®/PTFE

Check Valve Seat

A= Aluminum

C=Carbon Steel

S=Stainless Steel

T= PTFE

W=UHMW Polyethylene

Non-Wetted Material Options

A= Painted Aluminum

I= Cast Iron

J= Painted Aluminum

w/PTFE Coated Hardware

Y= Painted Aluminum

w/Stainless Steel Hardware

Z= Cast Iron with Stainless Steel Hardware

Porting Options

N=NPT Threads

B= BSPT (Tapered) Threads

Pump Style

S= Standard

Pump Options

0= None

1= Sound Dampening Muffler

2= Mesh Muffler

3= High temperature Air Valve

w/Encapsulated Muffler

4= High temperature Air

Valve w/Sound Dampening Muffler

5= High temperature Air Valve

w/Mesh Muffler

Kit Options

00.=None

P0.=0-30VDC Pulse Output Kit

P1.=Intrinsically-Safe 10-30VDC Pulse Output Kit

P2.=1 10/120 or 220/240VAC Pulse Output Kit

P3.=Intrinsically-Safe 110/120VAC Pulse Output Kit

P4.=Intrinsically-Safe 220/240VAC Pulse Output Kit

SP.=Stroke Indicator Pins

**CAUTION! Operating temperature limitations are as follows:**

Materials	Operating Temperatures	
	Maximum	Minimum
Buna N General purpose, oil-resistant. Shows good solvent, oil, water and hydraulic fluid resistance. Should not be used with highly polar solvents like acetone and MEK, ozone, chlorinated hydrocarbons and nitro hydrocarbons.	190°F 88°C	-10°F -23°C
EPDM Shows very good water and chemical resistance. Has poor resistance to oil and solvents, but is fair in ketones and alcohols.	280°F 138°C	-40°F -40°C
Neoprene All purpose. Resistant to vegetable oil. Generally not affected by moderate chemicals, fats, greases and many oils and solvents. Generally attacked by strong oxidizing acids, ketones, esters, nitro hydrocarbons and chlorinated aromatic hydrocarbons.	200°F 93°C	-10°F -23°C
Santoprene® Injection molded thermoplastic elastomer with no fabric layer. Long mechanical flex life. Excellent abrasion resistance.	275°F 135°C	-40°F -40°C
Virgin PTFE Chemically inert, virtually impervious. Very few chemicals are known to react chemically with PTFE: molten alkali metals, turbulent liquid or gaseous fluorine and a few fluoro-chemicals such as chlorine trifluoride or oxygen difluoride which readily liberate free fluorine at elevated temperatures.	220°F 104°C	-35°F -37°C
Viton® Shows good resistance to a wide range of oils and solvents; especially all aliphatic, aromatic and halogenated hydrocarbons, acids, animal and vegetable oils. Hot water or hot aqueous solutions (over 70°F) will attack Viton®.	350°F 177°C	-40°F -40°C
UHMW PE	180°F 82°C	-35°F -37°C
Polypropylene	180°F 82°C	32°F 0°C

For specific applications, always consult The Warren Rupp Chemical Resistance Chart

Dimensions: S1F Metallic

Dimensions in Inches
Dimensional Tolerance: $\pm 1/8"$

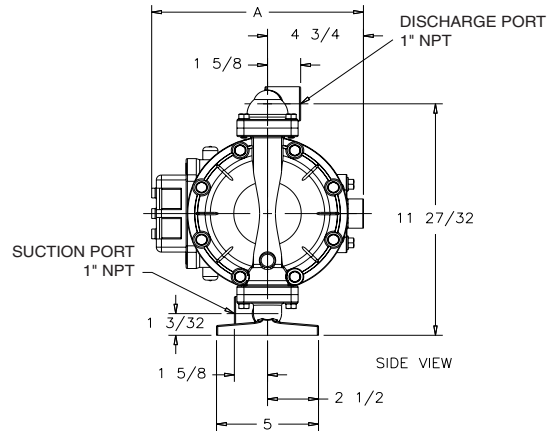
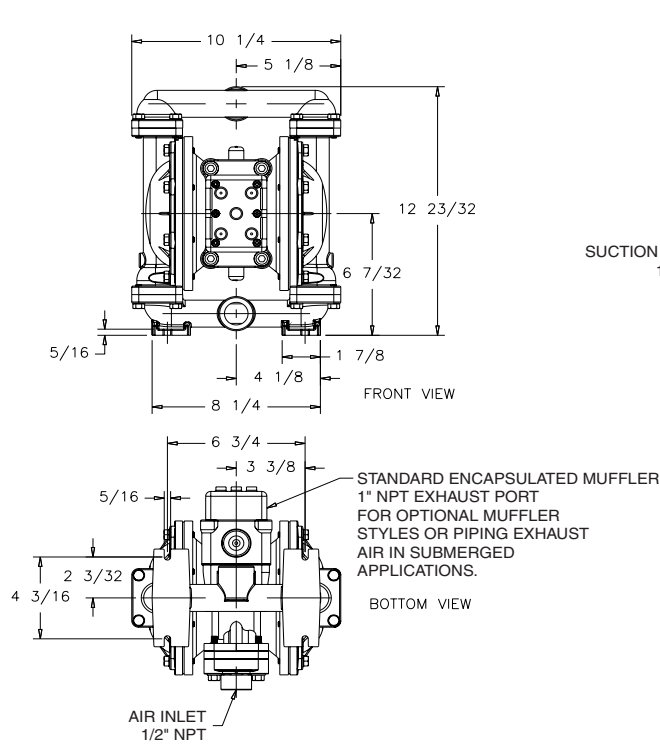

STANDARD PUMP SHOWN WITH 530-028-550 ENCAPSULATED MUFFLER
BOTH SUCTION AND DISCHARGE PORTS ARE AVAILABLE WITH 1" BSPT (TAPERED) THREADS

DIMENSION	A
Standard Pump	10 3/8
Pulse Output Kit	11 3/4
Mesh Muffler	12 7/8

Dimensions in Millimeters
Dimensional Tolerance: $\pm 3\text{mm}$

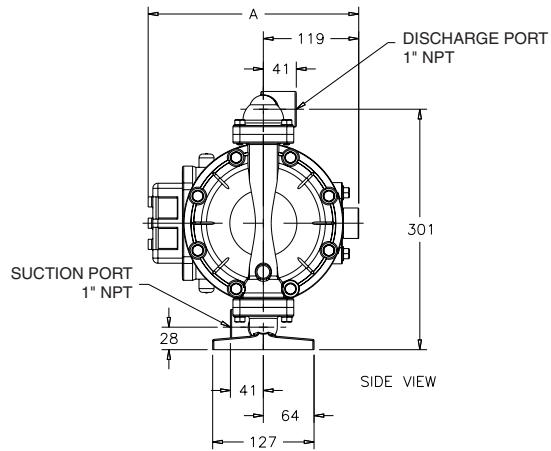
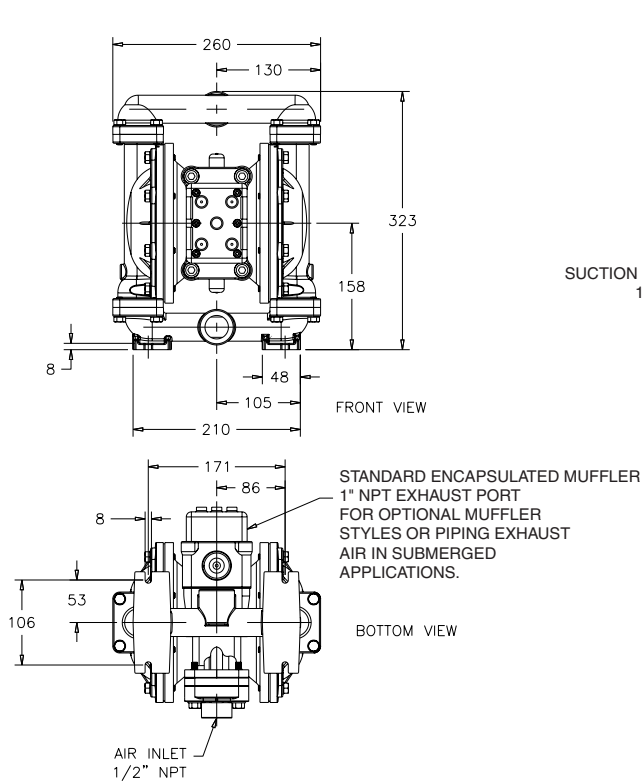

STANDARD PUMP SHOWN WITH 530-028-550 ENCAPSULATED MUFFLER
BOTH SUCTION AND DISCHARGE PORTS ARE AVAILABLE WITH 1" BSPT (TAPERED) THREADS

DIMENSION	A
Standard Pump	264
Pulse Output Kit	298
Mesh Muffler	327