

Pyxel Oil Supported Diaphragm Pump

Data sheet 124 GP 02
Issue 3

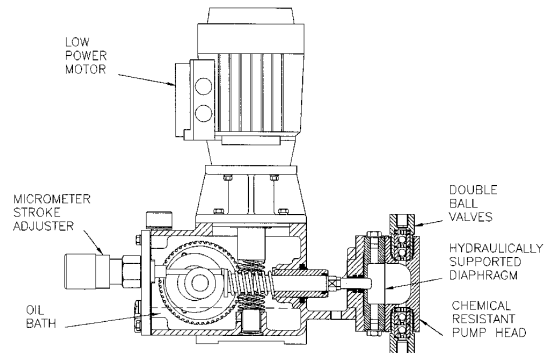

Nett weight - 21 kg

Size - 411 x 159 x 381 mm

The Pyxel Oil Supported Diaphragm pump is a variable output pump with high efficiency ball valves. High grade engineering plastics for wetted parts enable a wide range of aggressive liquids to be handled and the absence of any gland offers zero leakage. Drive from vertical mounted motor is through a worm and wheel to the eccentric which operates a cam. The cam actuates a spring return push rod. The stroke is set by a manual adjusting micrometer screw giving calibrated adjustment of length with a 13:1 turn down ratio.

Specifications

- ◆ **Size:** - Pumps are manufactured with 12.7mm stroke and piston diameters from 12mm to 38mm. Outputs of up to 50 L/Hr are achieved employing either three phase or single phase 0.18kW, 0.25kW or 0.37kW motors with pressures up to 70 Bar depending on materials of construction.
- ◆ **Speed:** - Standard electric motors of 1500 rpm are employed giving a pump speed of 60 strokes per minute. Alternative motors and speeds for non-standard electrical supplies can be supplied if required.
- ◆ **Materials of Construction:** - The gearbox is of high grade cast iron. Standard construction of the pump head, uPVC or 316 stainless with PTFE diaphragm and valve balls of glass, PTFE, ceramic or stainless steel. Other materials are available to special order. Standard units are suitable with liquids up to 60°C.
- ◆ **Typical Applications** - The Pyxel Oil Supported Diaphragm pump is ideal for chemical injection, water treatment dosing, sampling etc., in fact any application where economical positive feed of liquids is required.

Our policy is to continually develop and improve our products and we therefore reserve the right to modify pumps shown in this brochure without notice.